

N29 (Merida)

Naturstein klassisch



Abbildung: N29 (Merida)
Naturstein: Crema Marfil

Standard



Gesamtgewicht



Kamineinsatz

Lina 7363 h
NW-Leistung: 9 kW
Abgasstutzen: Ø 200 mm

Optional



Mehr Infos unter
camina-schmid.de

A

Zubehör

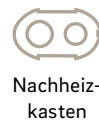

Naturstein

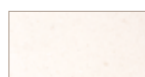
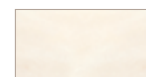
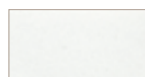
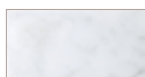

Frontansicht M 1:25

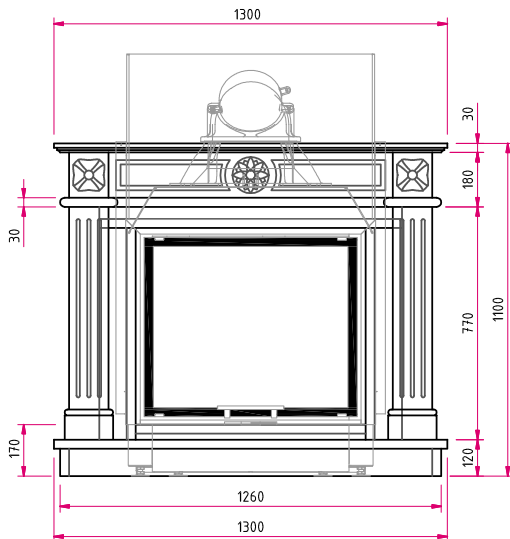

Seitenansicht M 1:25

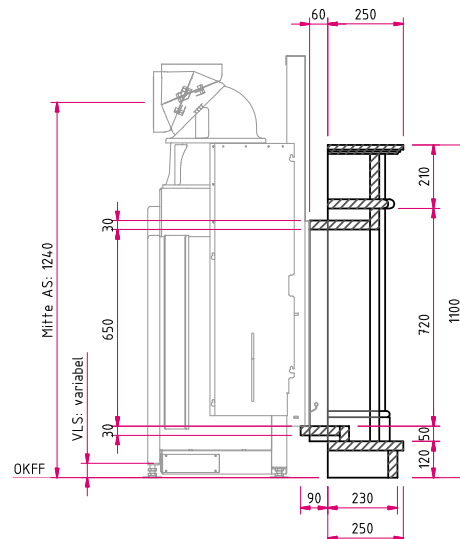

Hinweis: Mit **optionalem Zubehör** bitte die Angaben in den Preislisten beachten.
AS: Abgasstutzen, VLS: Verbrennungsluftstutzen, OKFF: Oberkante Fertigfußboden

Draufsicht M 1:25

